

Non-Destructive Evaluation of the Physical Properties in Packed Tofu using Time-Domain Diffuse Optical Spectroscopy

Yoshito Saito^{1,*}, Riku Miyakawa¹, Takumi Murai¹, Etsuko Ohmae^{2,3}, Kentaro Okuyama⁴, Hiroko Wada², Kenji Yoshimoto², Hiroaki Suzuki², and Yukio Ueda²

¹ Graduate School of Science and Technology, Niigata University, Niigata, Japan

² Hamamatsu Photonics K.K., Hamamatsu, Shizuoka, Japan

³ HAMAMATSU BioPhotonics Innovation Laboratory, Hamamatsu University School of Medicine, Hamamatsu, Shizuoka, Japan

⁴ Graduate School of Medical and Dental Sciences, Niigata University, Niigata, Japan

Email: ysaito@agr.niigata-u.ac.jp (Y.S.)

*Corresponding author

Manuscript received November 12, 2025; accepted December 1, 2025; published June 29, 2026

Abstract—The demand for packed tofu has been increasing globally in recent years. However, the manufacturing process lacks an established method for non-destructive evaluation of tofu coagulation and necessitating the disposal of a certain number of products for quality inspection. While Near-Infrared Spectroscopy (NIR) for estimating the reduced scattering coefficient (μ_s') has been reported as a non-destructive method for predicting tofu viscosity, previous studies have only conducted contact measurements on tofu, with no reports of measurements through packages. Therefore, this study aimed to evaluate non-destructive methods for measuring the physical properties of packed tofu. A total of 10 packed tofu samples were prepared with different coagulant concentrations, and both physical and optical measurements were conducted. Physical property measurements included viscosity, Water Holding Capacity (WHC), and solid content. Optical measurements utilized Time-Domain Diffuse Optical Spectroscopy (TD-DOS) to calculate the μ_s' and absorption coefficient (μ_a). Optical measurements were performed at three locations (direct, through-film, and bottom) with three source-detector distances (SD = 1 cm, 2 cm and 3 cm) at each location. Correlation analysis between viscosity and μ_s' yielded correlation coefficient exceeding 0.90 for both direct and bottom measurements at SD = 2 and 3 cm. Additionally, the scanning electron microscopy (SEM) of the tofu microstructure revealed that homogeneity of the microstructure increased with viscosity increase, which might have increased μ_s' . These results demonstrate that measuring μ_s' through the bottom of tofu's pack enables non-destructive evaluation of tofu.

Keywords—near-infrared spectroscopy (NIRS), packed tofu, reduced scattering coefficient, Time-Domain Diffuse Optical Spectroscopy (TD-DOS), viscosity

I. INTRODUCTION

Tofu is one of the most important soybean-derived products and has been traditionally consumed, particularly in Asia. Tofu has several advantages: it is high in protein, low in fat, low in calories, and highly nutritious [1]. In recent years, tofu has gained a global attention, not only in Asia but also worldwide, due to the increase in non-meat diets and growing health consciousness. Consequently, there is a demand for stable production of high-quality tofu.

The tofu manufacturing process mainly consists of soymilk extraction from soybeans, mixing soymilk with coagulants, heating for coagulation, cutting and packaging. Among these steps, the coagulation process is the most critical process that affects the quality of tofu. During coagulation, protein

particles in soymilk aggregate around lipid bodies, forming a microstructure called curd that retains water internally [2]. Generally, the microstructural characteristics of porous foods such as noodles and bread, which have a similar structure to tofu, significantly influence their physical properties [3]. In the case of tofu, physical properties are considered one of the most important aspects of tofu quality and are evaluated by factors such as hardness, viscosity, elasticity and water holding capacity (WHC). The coagulation process is influenced by various interacting factors, including soymilk quality, coagulant types and concentrations, heating time, heating temperature and stirring speed, which makes it difficult to achieve the desired coagulation [4]. In particular, the level of coagulation is greatly affected by the concentration and type of coagulant, as well as the soybean variety used [5]. Currently, in many factories, the coagulation process is managed based on the experience and intuition of skilled workers. Therefore, instability in the physical properties of tofu has become a problem.

Recently, the demand for packed tofu (Filled tofu) has been increasing. Packed tofu, unlike traditional methods, is produced by packaging soymilk with the coagulant before coagulation and then heating the entire package. This method has advantages such as being more hygienic as it doesn't require human contact, and it has a longer shelf life. However, packed tofu differs from conventional tofu in that it is packaged before coagulation, making it difficult to check the internal state after heating. Traditionally, the coagulation state could be checked by directly touching the tofu, but with packed tofu, there is no method to confirm the coagulation state through the package. This results in waste during the production process because a certain number of packages must be opened and discarded for coagulation checks. Moreover, to avoid the risk of uncoagulated packed tofu reaching the market, constant human monitoring for coagulation verification is necessary, which requires enormous labor and financial costs. Consequently, there is a demand for non-destructive sensing technology to determine the coagulation state of packed tofu.

Electrical impedance spectroscopy is known as a simple and rapid method for measuring the coagulation process of soymilk and can be used to monitor the coagulation process [6]. However, it is limited to contact measurements of the sample, posing a significant challenge because it is a

destructive measurement method. One of the previous studies has reported the possibility of predicting tofu coagulation state by the reduced scattering coefficient (μ_s') using spatially resolved diffuse reflectance spectroscopy with a 633 nm wavelength [7]. Another study used transmission measurements of 1300-1800 nm infrared light and Mie approximation to estimate μ_s' , exploring the possibility of predicting coagulation with different coagulation temperatures and times [8]. Previous studies have estimated the μ_s' using optical measurement techniques and demonstrated its correlation with the coagulation state of tofu. However, these methods often require invasive procedures, such as the addition of ink, or rely on complex measurement protocols involving near-infrared spectrophotometers. Consequently, conventional optical approaches are not well-suited for achieving fully non-destructive coagulation assessment in commercially packaged tofu.

As one of the accurate optical methods, Time-Domain Diffused Optical Spectroscopy (TD-DOS) is a method that directly measures the absorption coefficient (μ_a) and μ_s' of samples with time-resolved spectroscopy. Previous studies have reported that TD-DOS system with near-infrared wavelength lasers can measure physiological parameters such as the oxy-, deoxy-hemoglobin concentrations, water, and lipid in living tissues from μ_a [9]. Furthermore, μ_s' has been used as an index reflecting the microstructure of neonatal brain tissue [10, 11]. However, no previous studies have reported adopting TD-DOS for measurements of packed tofu through the packages.

Therefore, the objective of this research is non-destructive evaluation of the physical properties in packed tofu using TD-DOS. In the experiments, packed tofu samples were prepared with different amounts of coagulant. For physical property measurements, viscosity, WHC, and solid content were measured. Optical property measurements using six-wavelength TD-DOS system (TRS-21-6W, Hamamatsu Photonics K.K., Japan) and microstructure observations were conducted. To evaluate the optimum measurement position, TD-DOS was measured at three locations: through the package film, directly on the tofu, and at the bottom of the pack. Furthermore, Scanning Electron Microscopy (SEM) for microstructure observations was conducted. Subsequently, the optical properties obtained on each position were compared with viscosity and microstructure to investigate potential correlations.

II. MATERIALS AND METHODS

A. Preparation of Packed Tofu Samples

In this study, soymilk (variety: 'Nakasennari', Kahei Tofu Corp, Japan) and crude-refined seawater bittern (main component: MgCl₂, Uminosei Corp, Japan) as coagulant, were used to make tofu samples. The different patterns of coagulant concentration were added to 1 L of soymilk and thoroughly mixed. To suppress the coagulation reaction during the stirring process, chilled soymilk was used. The mixture was then poured into a 200 ml plastic pack and packaged using a packaging machine. Subsequently, the samples were heated at 80 °C for 40 minutes in a water bath, and then cooled and refrigerated until measurement. For each coagulant concentration, five replicated samples were

prepared: two for optical property measurements, two for physical property measurements and one for SEM analysis. Table 1 shows the coagulant concentration patterns for the tofu samples.

Table 1. Coagulant concentrations in packed-tofu samples

No.	Amount of coagulant (g/L)
1	5.00
2	5.75
3	6.50
4	7.25
5	8.00
6	8.75
7	9.50
8	10.25
9	11.00
10	11.75

B. Measurement of the Physical Properties

Viscosity was measured using the method proposed by Saito *et al.* [8]. Measurements of the tofu sample was measured at room temperature (22 °C) using a tuning fork vibration viscometer SV-10 (A&D, Japan). Considering variations within the same sample, viscosity measurements were performed three times for each sample, and all samples were measured under the same conditions.

WHC was measured using the method proposed by Onodera *et al.* [12]. The tofu sample was cut to a thickness of 1 cm, then three cylindrical pieces were created using an inner diameter of 19 mm hole punch (TRUSCO, Japan). These were placed on aluminum foil and weighed, then left on a tray lined with sufficiently thick towels for one hour. They were then weighed again on the same aluminum foil to measure the WHC per hour. The samples used for WHC measurement were then placed in an incubator (ONW-450SB, TRUSCO, Japan) heated to 105 °C for 24 hours to completely evaporate the water in the tofu, and the weight was measured. The WHC was calculated from the obtained measurements using the following equation, where W_w is the initial weight of the tofu, W_a is the weight of the tofu after one hour, and W_d is the weight of the dried tofu:

$$\text{WHC}(\%) = \frac{W_a - W_d}{W_w - W_d} \quad (1)$$

The solid content was calculated from the measurements obtained using the following equation:

$$\text{Solid content} = \frac{W_d}{W_w} \quad (2)$$

C. Optical Measurement

TD-DOS measurement was conducted using TRS-21-6W developed for measuring optical properties: μ_a and μ_s' [9]. The configuration of the system is shown in Fig. 1. The system consists of six-wavelength picosecond pulsers (PLPs; 762, 801, 836, 908, 934, and 975 nm), two photomultiplier tubes (PMTs), time-correlated single-photon counting (TCSPC) unit, a trigger source board, optical bundles, personal computer, and a touch-panel display. Each photodetector unit comprises a Variable Optical Attenuator (VOA), a Gallium Arsenide (GaAs) or indium gallium

arsenide (InGaAs) PMT, and a high-speed amplifier. TCSPC unit comprises a constant Fraction Discriminator (CFD), a Time-to-Amplitude Converter (TAC), an Analog-to-Digital (A/D) converter, and histogram memory. The system based on the TCSPC method acquires the temporal profile of the detected light.

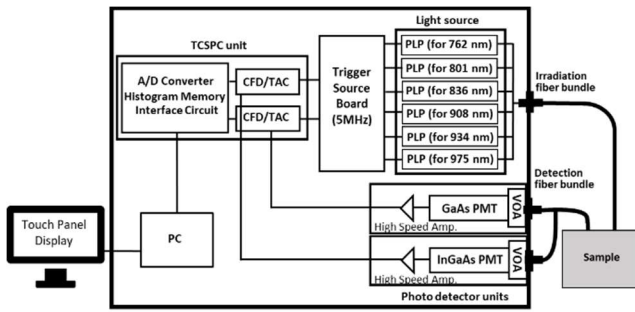

Fig. 1. TRS-21-6W configuration.

Analyzing the temporal profile according to photon diffusion theory [13], the system provides the optical properties of samples. An estimated profile is calculated by convolving the instrument response function with an analytical solution of the photon diffusion equation for a homogeneous medium, and then the μ_a and μ_s' of the sample are determined by fitting the estimated profile to the measured profile with a non-linear least squares method based on the Levenberg-Marquardt algorithm. The equation of the photon diffusion theory has the analytical solution which can be described in Eq. (3).

$$R(d, t) = (4\pi Dc)^{-\frac{2}{3}} z_0 t^{-\frac{5}{2}} \exp(-\mu_a ct) \exp\left(-\frac{d^2 + z_0^2}{4Dct}\right) \quad (3)$$

where d is the source-detector distance (SD) on the sample surface, $z_0 = 1/(\mu_a + \mu_s')$ is the transport mean free path, $D = 1/3((\mu_a + \mu_s'))$ is the photon diffusion equation and c is the speed of light in the sample. The details of analyzing the temporal profiles have also been described previously [9].

The TD-DOS system can quantify the optical properties of samples by analyzing time profiles measured in reflectance and transmittance geometries. In this study, reflectance geometry measurements were conducted under three conditions of SDs: 1, 2 and 3 cm, to determine the optimal SD. For packed tofu measurements, three positions were employed at each measurement point to verify the optical properties: through the film, at the bottom of the pack and directly on the tofu. Thus, a total of nine conditions were measured, combining SD and measurement locations. All measurements were performed on two replicated samples with acquisition times ranging from 5 to 8 seconds.

D. SEM Image Acquisition and Image Analysis

To examine differences in the microstructure of tofu, SEM was used to obtain microscopic images. The tofu samples were pre-treated before SEM image acquisition using the method proposed by Onodera *et al.* [12]. The samples were cut to a thickness of 1 mm at a position 1 cm below the surface, immersed in 1% glutaraldehyde solution for 1 hour to fix the tissue. They were then washed with distilled water, flash-frozen with liquid nitrogen, and freeze-dried for 72 hours at a

pressure below 50 Pa using a freeze dryer (FDU-12AS, ASONE, Japan). Ion sputtering equipment E-1030 (Hitachi, Japan) was used to add platinum palladium to the dried sample surface. For SEM image acquisition, S-4300SE/N (HITACHI, Japan) was used. The acceleration voltage was 10 kV and the magnification was $\times 1000$. All the samples were pretreated and analyzed by SEM but, due to effects such as electrical charging on the sample surface and SEM image fluctuation, measurements were only successfully performed for sample No.6, 7, 9, and 10.

Subsequently, from the obtained SEM images, geometric parameters including the number of holes per unit area, average hole size and porosity were calculated using the image analysis to quantify the microstructural characteristics of packed tofu [14]. To separate all pixels into foreground and background pixels, Otsu's method was applied to determine the threshold for dividing the grayscale image into a binary image. Here, adaptive thresholding was applied to account for spatial variations in illumination [15]. After removing small objects, area opening was applied to remove all connected components smaller than 40 pixels. Since holes are related to the free cavities between protein structures in the curd, the number of holes per unit area and the average hole size were calculated. Porosity was calculated as the ratio of holes to the total image area.

III. RESULT AND DISCUSSION

A. Physical Properties

The results of the viscosity measurements are shown in Fig. 2(a). As shown in Fig. 2(a), there was a gradual increase in viscosity from Sample No.1 to No.10. This result is because the amount of coagulant was increased from No.1 to No.10 when sample preparation. Additionally, previous studies have reported that an increase in coagulant amount leads to increased viscosity, which is consistent with the results in this study [16].

The results of the WHC and solid content measurements are shown in Fig. 2(b) and Fig. 2(c). As shown in Fig. 2(b), the WHC graph shows a hill-like shape with the maximum value in Sample No.8. Previous studies have reported that the microstructure of tofu affects the WHC [12]. Samples No.1 and No.2 had low WHC due to oversized curd structures, while samples No.7 and No.8 had high WHC due to the formation of uniform size of curds. For No.9 and No.10, it is thought that the WHC decreased due to too much coagulant. It is predicted that further increasing the coagulant amount beyond that of No.10 would result in an even lower WHC.

As shown in Fig. 2(c), the solids concentration was almost constant for all samples. This may be because the soymilk samples provided in this study had the same concentration.

B. Optical Measurements Results

The effect of changing SD distances (SD = 1 cm, 2 cm and 3 cm) on measurement results was investigated at each measurement location. Fig. 3 shows the results of μ_s' for different SD distances under direct measurement conditions. Representative results for 3 wavelengths: 762, 801 and 908 nm were shown where the error bars represent the standard deviation.

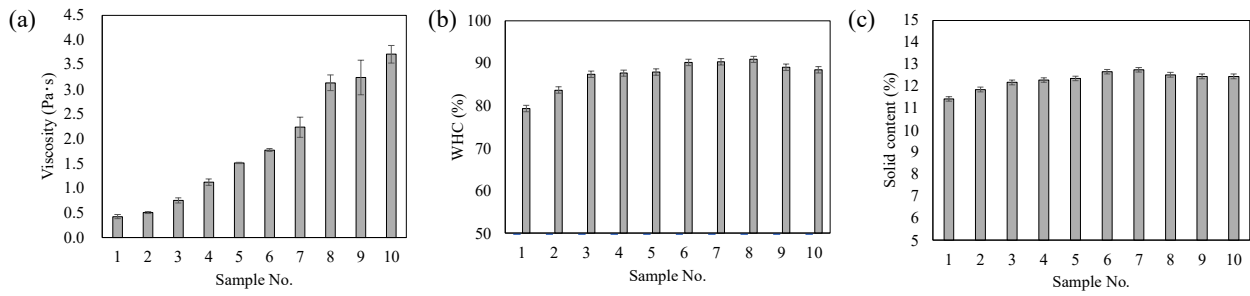

Fig. 2. The results of physical properties measurements: (a)Viscosity, (b)WHC, (c)Solid content.

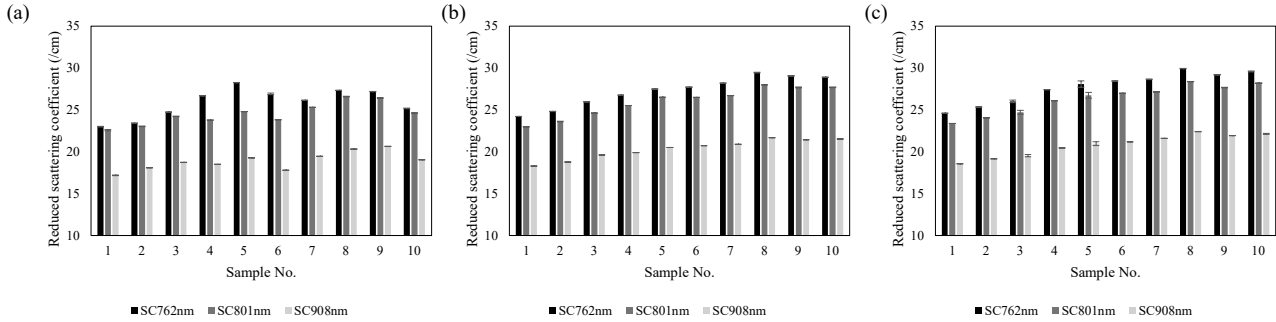

Fig. 3. The results of reduced scattering coefficient obtained from a direct measurement position at SD = (a) 1cm, (b) 2cm and (c) 3cm. The error bars represent the standard deviation.

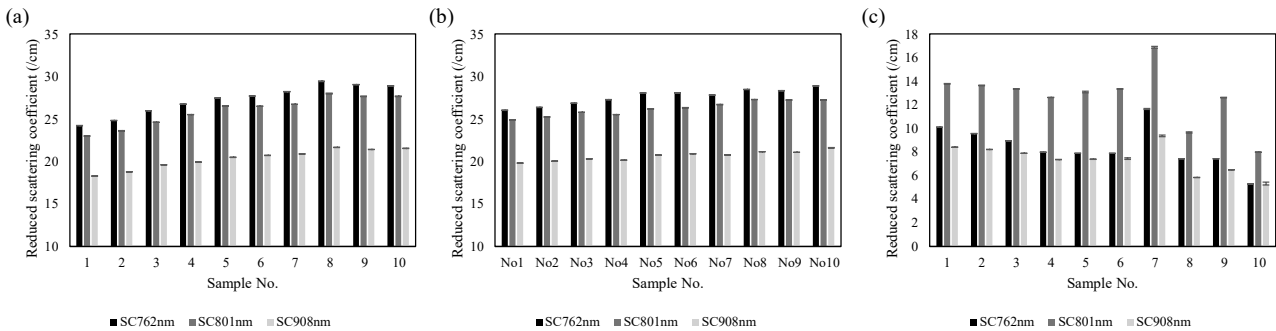

Fig. 4. The results of reduced scattering coefficient at different measurement locations: (a) direct, (b) bottom, (c) through-film. The error bars represent the standard deviation.

As shown in Fig. 3(a), at SD = 1 cm, μ_s' was maximum at sample No.5. On the other hand, at SD = 2 cm and 3 cm, μ_s' increased from No.1 to 10 for all wavelengths as shown in Fig. 3(b) and Fig. 3(c). Previous studies have reported that in tofu with high viscosity, the curd structure becomes dense, leading to an increase in light scattering in near-infrared wavelength regions [7]. Additionally, previous studies have reported that during yogurt fermentation from milk, the reduced scattering coefficient increased with the coagulation process [17, 18]. This phenomenon parallels the optical behavior observed in our tofu coagulation study. Considering that viscosity increased from sample No.1 to 10 as shown in Fig. 2(a), it appears that SD = 2 and 3 cm were appropriate for measuring μ_s' in tofu samples. The measurement results at SD = 1 cm did not align with previous studies and were likely inappropriate conditions. The reason for this discrepancy at SD = 1 cm could be that the penetration depth was not enough, as previous studies have reported that longer SDs allow for the detection of photons that have penetrated deeper into the sample.

Fig. 4 shows the results of μ_s' at different measurement locations. Representative results for 3 wavelengths at SD = 2 cm were shown. Fig. 4(a), (b) and (c) shows direct measurements, bottom surface measurements and film measurements results, respectively. As shown in Fig. 4, direct measurements resulted in an increase in μ_s' from No.1 to 10

for all wavelengths. Bottom surface measurements showed a similar trend. However, in Fig. 4(c), measurements on the film showed large variations between wavelengths with no specific tendency. This may be due to the film material of the tofu pack allowing easy propagation of photons.

C. Correlation Coefficients between Physical Properties and Optical Coefficients

To investigate the potential of the optical measurements for quality evaluation in the packed tofu, the correlation between μ_s' and physical properties was investigated. Among the three physical properties measured in this study: viscosity, WHC and solid content, viscosity demonstrated the strongest correlation with μ_s' . Table 2 shows the correlation coefficient (r) between viscosity and μ_s' under each measurement conditions.

As shown in Table 2, the direct and bottom measurements yielded higher r than on the film. Presumably this is because photon propagation along the film surface leading to measurement instability. As shown in Table 2, SD = 2 and 3 cm exhibited higher r compared to SD = 1 cm. This enhancement in correlation at longer SDs can be attributed to the detection of photons that have penetrated deeper into the sample, thereby providing more comprehensive internal structural information. Also, minimal variation in r was observed across different wavelengths.

Furthermore, based on the Instrument Response Function (IRF) and measured values, the average optical path length was calculated, and the average values of the mean optical path length (PL) for each measurement item at each measurement wavelength were determined. The results are shown in Table 3. As shown in Table 3, it was confirmed that PL tends to increase as SD rises. Additionally, the results showed that the average optical path length was larger at shorter wavelengths than at longer wavelengths. This is thought to be caused by shorter wavelengths undergoing more scattering events, increasing the distance traveled. For SD = 3 cm in both direct and bottom measurements, the average optical path length exceeded 60 cm at its maximum. Considering the thickness of the tofu pack is approximately 2 cm, it was possible that photons were passing through the tofu pack. These results suggest that SD = 2 cm, which has a high correlation with viscosity and an average optical path length within 40 cm, may be optimal.

These findings indicate that both direct and bottom surface measurements effectively characterize the samples' physical properties. Furthermore, these results suggest that bottom surface measurements represent a viable approach for non-destructive analysis.

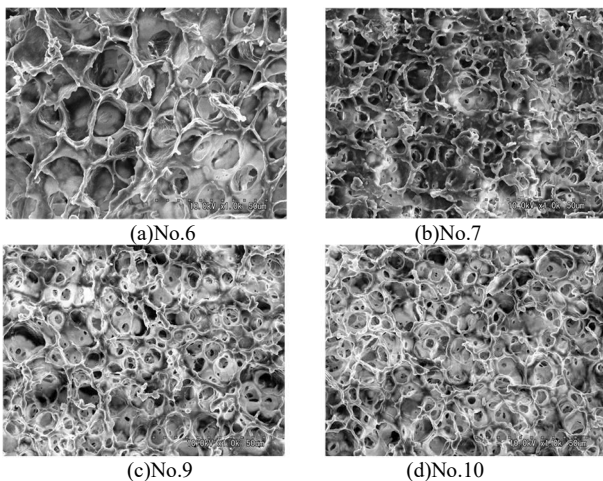

Fig. 5. Acquired SEM images of tofu samples, where (a) was made with coagulant concentration of 8.75 (g/L), (b) was 9.5 (g/L), (c) was 11.00 (g/L) and (d) was 11.75 (g/L). The magnification was $\times 1000$.

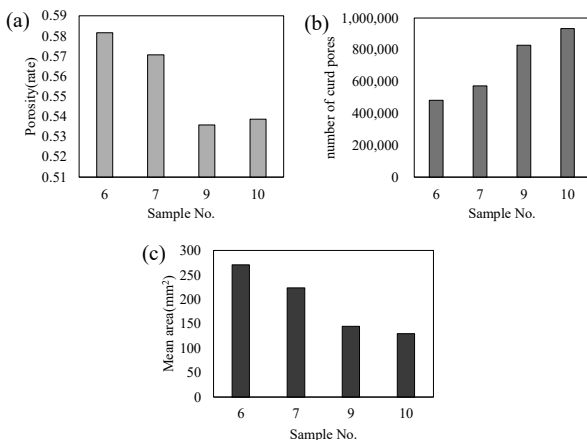

Fig. 6. SEM image analysis results, where (a) was Porosity, (b) was Number of curd pores and (c) was Mean area.

Table 2. Correlation coefficient between $\mu s'$ and viscosity for each measurement condition

Position	SD (cm)	Wavelength (nm)					
		762 nm	801 nm	836 nm	908 nm	934 nm	975 nm
Direct	1	0.77	0.82	0.85	0.87	0.87	0.87
	2	0.91	0.91	0.91	0.91	0.91	0.91
	3	0.94	0.95	0.95	0.96	0.96	0.96
Film	1	-0.31	-0.31	-0.30	-0.26	-0.25	-0.25
	2	-0.76	-0.80	-0.83	-0.64	-0.44	-0.29
	3	0.55	0.56	0.58	0.62	0.63	0.63
Bottom	1	0.84	0.81	0.78	0.73	0.71	0.70
	2	0.96	0.97	0.98	0.98	0.98	0.98
	3	0.96	0.95	0.95	0.93	0.92	0.91

Table 3. The mean optical path length (cm) in each measurement condition

Position	SD (cm)	Wavelength (nm)					
		762 nm	801 nm	836 nm	908 nm	934 nm	975 nm
Direct	1	15.3	15.9	13.6	9.9	7.7	5.0
	2	37.8	40.0	33.5	23.9	17.9	11.5
	3	60.3	63.4	53.2	38.3	28.7	18.8
Bottom	1	14.9	15.2	13.3	9.5	7.5	4.5
	2	38.2	40.4	33.9	24.2	18.2	11.0
	3	60.2	63.3	53.1	38.0	28.5	22.4
Film	1	14.9	15.4	13.2	9.8	7.7	4.5
	2	29.9	33.8	27.7	19.1	11.6	4.3
	3	35.7	44.6	33.6	20.2	9.2	5.1

D. Scanning Electron Microscope (SEM) Imaging and Analysis

Fig. 5 shows the acquired SEM images, where Fig. 5(a), (b), (c) and (d) respectively represent the SEM images of sample No.6, 7, 9 and 10. As shown in Fig. 5, the circular curd structures were observed in each SEM image. In No.6, individual curd pores were large, while from No.7 to No.10, there was a trend of decreasing the pore size in curd structure. This means the microstructure of tofu got finer as the coagulant concentration increased, which was consistent with a previous study [7].

In this study, porosity, number of curd pores and mean area of curd pores were calculated from the acquired SEM images based on the methods reported by a previous study [8]. The results are shown in Fig. 6. Fig. 6(a), (b) and (c) shows porosity, number of curd pores and mean area of curd pores, respectively.

As shown in Fig. 6(a), porosity showed a decreasing trend from No.6 to 10. This might mean that the addition of more amount of coagulant decreased the porosity due to the coagulation of a larger amount of protein in soymilk. On the other hand, the number of pores showed an increasing trend from No.6 to No.10, which is consistent with the SEM image trends. The mean area of curd pores showed a decreasing trend from No.6 to 10, also consistent with the SEM image trends. Therefore, it was clarified that the microstructure in tofu became denser with higher viscosity and more coagulant added. In addition, the smaller size of the periodic microstructure may have increased the number of times in light scattering, resulting in a larger $\mu s'$.

IV. CONCLUSIONS

This study investigated the potential of Time-Domain Diffuse Optical Spectroscopy (TD-DOS) for a non-destructive measurement method for packed tofu. A total of 10 packed tofu samples with different coagulant

concentrations were prepared, and the physical properties and optical coefficients were measured. Optical measurements at source-detector distances of 2 and 3 cm from both direct and bottom positions showed strong correlations ($r > 0.90$) between the reduced scattering coefficient and viscosity. Furthermore, the microstructure got fine and dense with increasing coagulant concentration, which was consistent with the physical property results. These results demonstrate that TD-DOS can non-destructively evaluate the physical properties of packed tofu through packaging. Future research should focus on expanding sample size and further validation of measurement conditions.

CONFLICT OF INTEREST

The authors declare no conflict of interest.

AUTHOR CONTRIBUTIONS

Yoshito Saito designed experiments, made samples, conducted laboratory analyses, data collection, statistical analysis, manuscript writing and revisions; Riku Miyakawa conducted laboratory analyses, data collection, statistical analysis and manuscript writing; Takumi Murai conducted laboratory analyses and data collection. Kentaro Okuyama designed experiments of SEM image acquisition; Etsuko Ohmae, Hiroko Wada, Kenji Yoshimoto, Hiroaki Suzuki and Yukio Ueda conducted laboratory analyses and data collection. All authors had approved the final version.

FUNDING

This work was supported in part by JSPS KAKENHI Grant Numbers JP23K14044 and JP25K02127, Japan.

REFERENCES

- [1] M. Pal, M. Devrani, and Y. Ayele, "Tofu: A popular food with high nutritional and health benefits," *Food & Beverages Processing*, vol. 5, no. 4, pp. 54–55, 2019.
- [2] T. Ono, "The mechanism of soymilk and tofu formation from soybean, and the factors affecting the formation," *Journal of the Japanese Society for Food Science and Technology*, vol. 55, no. 2, pp. 39–48, 2008.
- [3] A.-F. Ammar, H. Zhang, A. Siddeeg, M. V. M. Chamba, B. G. Kimani, H. Hassanin, M. Obadi, and N. Alhejj, "Effect of the addition of alhydwan seed flour on the dough rheology, bread quality, texture profile and microstructure of wheat bread," *J. Texture Stud.*, vol. 47, no. 6, pp. 484–495, 2016.
- [4] H. J. Hou, K. C. Chang, and M. C. Shih, "Yield and textural properties of soft tofu as affected by coagulation method," *J. Food Sci.*, vol. 62, no. 4, pp. 824–827, 1997.
- [5] M. P. Prabhakaran, C. O. Perera, and S. Valiyaveetil, "Effect of different coagulants on the isoflavone levels and physical properties of prepared firm tofu," *Food Chemistry*, vol. 99, no. 3, pp. 492–499, Jan. 2006.
- [6] X. Li, K. Toyoda, and I. Ihara, "Coagulation process of soymilk characterized by electrical impedance spectroscopy," *J. Food Eng.*, vol. 105, no. 3, pp. 563–568, Aug. 2011.
- [7] Y. Saito, K. Konagaya, T. Suzuki, and N. Kondo, "Determination of optical coefficients of tofu using spatially resolved diffuse reflectance at 633 nm," *Engineering in Agriculture, Environment and Food*, vol. 11, no. 1, pp. 38–42, Jan. 2018.
- [8] Y. Saito, T. Suzuki, and N. Kondo, "Evaluation of optical properties of tofu samples produced with different coagulation temperatures and times using near-infrared transmission spectroscopy," *Infrared Phys. Technol.*, vol. 123, pp. 104149, June 2022.
- [9] E. Ohmae, N. Yoshizawa, K. Yoshimoto, M. Hayashi, H. Wada, T. Mimura, H. Suzuki, S. Homma, N. Suzuki, H. Ogura, H. Nasu, H. Sakahara, Y. Yamashita, and Y. Ueda, "Stable tissue-simulating phantoms with various water and lipid contents for diffuse optical spectroscopy," *Biomed Opt Express*, vol. 9, no. 11, pp. 5792–5808, Nov. 2018.
- [10] S. Ijichi, T. Kusaka, K. Isobe, K. Okubo, K. Kawada, M. Namba, H. Okada, T. Nishida, T. Imai, and S. Itoh, "Developmental changes of optical properties in neonates determined by near-infrared time-resolved spectroscopy," *Pediatr Res*, vol. 58, no. 3, pp. 568–573, Sept. 2005.
- [11] N. Iwata-Yoshikawa, N. Shiwa, T. Sekizuka, K. Sano, A. Ainai, T. Hemmi, M. Kataoka, M. Kuroda, H. Hasegawa, T. Suzuki, and N. Nagata, "A lethal mouse model for evaluating vaccine-associated enhanced respiratory disease during SARS-CoV-2 infection," *Sci Adv*, vol. 8, no. 1, p. eabh3827, Jan. 2022.
- [12] Y. Onodera, T. Ono, K. Nakasato, and K. Toda, "Homogeneity and microstructure of tofu depends on 11S/7S globulin ratio in soymilk and coagulant concentration," *Food Sci. Technol. Res.*, vol. 15, no. 3, pp. 265–274, 2009.
- [13] M. S. Patterson, B. Chance, and B. C. Wilson, "Time resolved reflectance and transmittance for the noninvasive measurement of tissue optical properties," *Appl. Opt.*, vol. 28, no. 12, p. 2331, June 1989.
- [14] Y. Saito, W.-H. Chiang, N. Kondo, T. Suzuki, "Quantitative analysis of tofu microstructure with different coagulant concentrations based on geometric parameters and haralick texture features," *Journal of the Japanese Society of Agricultural Machinery and Food Engineers*, vol. 83, pp. 95–104, 2021.
- [15] D. Bradley and G. Roth, "Adaptive thresholding using the integral image," *Journal of Graphics Tools*, vol. 12, no. 2, pp. 13–21, 2007.
- [16] Y. Nakazawa, "Evaluation of suitability of Tofu-making with different kinds and concentrations of coagulants," *Report of the Kyushu Branch of Jpn. J. Crop. Sci.*, pp. 89–91, May 2005.
- [17] O. H. A. Nielsen, A. A. Subash, F. D. Nielsen, A. B. Dahl, J. L. Skytte, S. Andersson-Engels, and D. Khoptyar, "Spectral characterisation of dairy products using photon time-of-flight spectroscopy," *J. Near Infrared Spectrosc.*, JNIRS, vol. 21, no. 5, pp. 375–383, Oct. 2013.
- [18] O. H. A. Abildgaard, F. Kamran, A. B. Dahl, J. L. Skytte, F. D. Nielsen, C. L. Thomsen, P. E. Andersen, R. Larsen, and J. R. Frisvad, "Non-invasive assessment of dairy products using spatially resolved diffuse reflectance spectroscopy," *Appl. Spectrosc.*, vol. 69, no. 9, pp. 1096–1105, Sept. 2015.

Copyright © 2026 by the authors. This is an open access article distributed under the Creative Commons Attribution License which permits unrestricted use, distribution, and reproduction in any medium, provided the original work is properly cited ([CC BY 4.0](https://creativecommons.org/licenses/by/4.0/)).